

Bearing Unit

PL50-155/5H-M30x1.5-LH

Bearing Unit
Disc Harrow

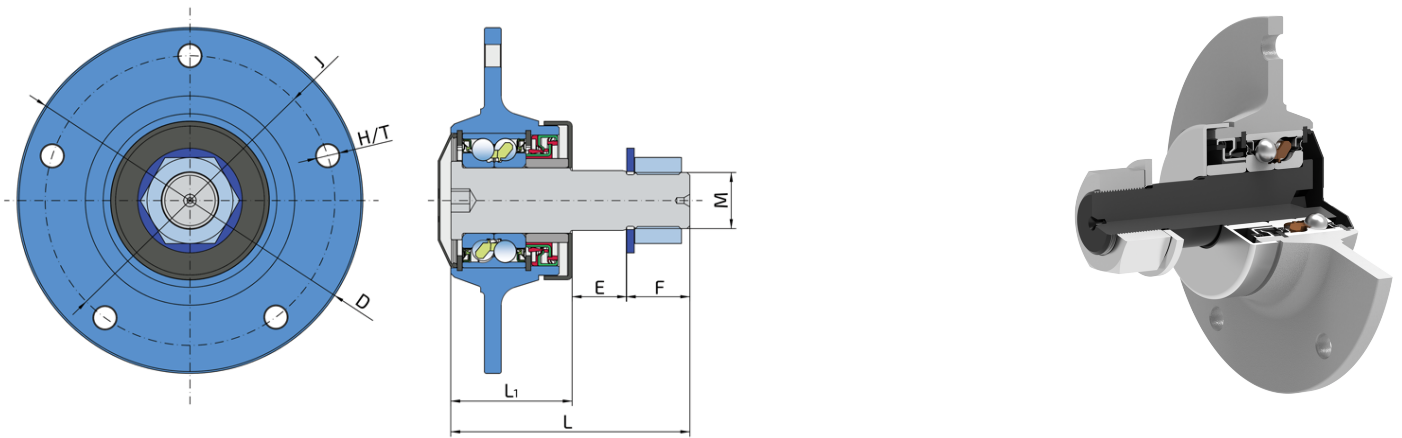

Technical Specification

D	Outside diameter	185 mm
J	Pitch circle diameter	155 mm
H/T	Hole/Thread	5x12 mm
L	Total length	128 mm
L1	Total flange length	65 mm
F	Length of threaded part	34 mm
M	Outer Thread	M30x1.5-LH mm
E	Length of D shape	30 mm
kg	Mass	4.228 kg
Cdyn	Dynamic load rating	47.4 kN
Co	Static load rating	38.3 kN
Pu	Fatigue load limit	1.609 kN

Sealing

PLASTIC CAP + CASSETTE SEAL / CASSETTE SEAL + DIRTBLOCK SEAL + METAL SHIELD

Two part double lip wheel bearing seal on the both side. This sealing provides excellent protection from contamination and low friction.

Front side is totally sealed with a polypropylene shield which prevents all kind of contaminations.

The other side is additionally protected with dirtblock seal and with a metal protective cap. Dirtblock seal is designed for hard working condition, half metal – half rubber outside diameter provides reliable seal retention in the bore and improves sealing performance. Inside diameter is covered by rubber and improves sealing performance and easy installation. The metal protective cap protects the seal from mechanical damage and from entanglement of grass stems of plants and twines.

This sealing provides maximum protection against liquid or solid contaminants, which significantly extends bearing service life.

